

sanitary centrifugal pump

Manual

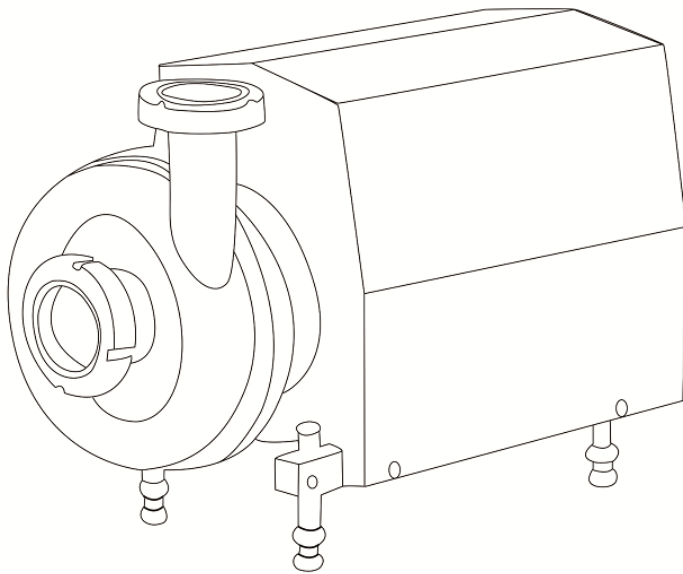

I .Safety

1. Important Information

Always read the manual before using the pump!

- 1). Indicates that special procedures must be followed to avoid severe personal injury.
- 2). Indicates that special procedures must be followed to avoid damage to the pump.
- 3). Indicates important information to simplify or clarify.

2. Safety Precautions

Installation:

Always read the technical data thoroughly. (See Page 17)

Always remove pump casing before deliver the pump. use a lifting crane when handling big size pump.

-Always have the pump electrically connected by authorized personnel. (See the motor instructions).

Always remove the impeller before checking the direction of rotation.

Never start the pump if th-e impeller is fitted and the pump casing is removed.

Operation:

The motor will be overload if the flow, concentration and viscosity of the liquid exceed the value in the parameter sheet. It will cause motor overloaded.

Never touch the pump or the pipelines when pumping hot liquids or when sterilizing.

Never run the pump with both the suction side and the pressure side blocked.

Always handle alkali and acid with great care.

Maintenance:

Always disconnect the power supply when servicing the pump.

-Never service the pump when it is hot.

-Never service the pump with pump and pipelines under pressure.

II .Installation

1.Unpacking/Delivery

Attention!

We cannot be held responsible for incorrect unpacking.

Step 1 Check the delivery for:

1. Pump surface in good condition.
2. Parts on packing list.
3. pump intruction
4. Motor instruction.

Step 2

Remove possible packing materials from the inlet and the outlet.

Inspect the pump for visible transport damages.

Make sure pump inlet and outlet are in good condition.

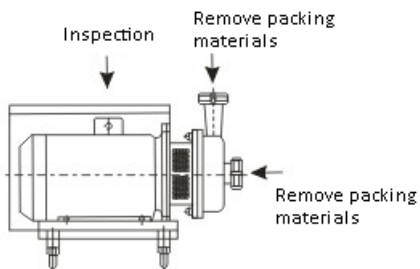

Step 3

Always remove pump casing before move the pump. Always use a lifting crane when handling big size pump.

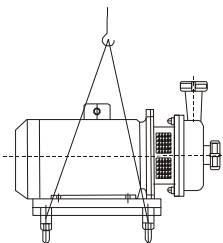

Remover the pump casing, if fitted, before lifting the pump.

2. Installation

Step 1

Please use a lifting crane when handling large size pump.

Always have the pump electrically connected by authorized personnel (see the motor instructions)

We cannot be held responsible for incorrect installation.

Step 2

Ensure that there is sufficient space around the pump (min.0.3-0.5m)

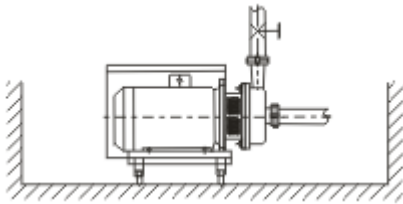

Step 3

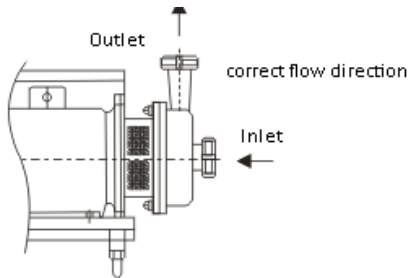

Ensure correct flow direction

Step 4

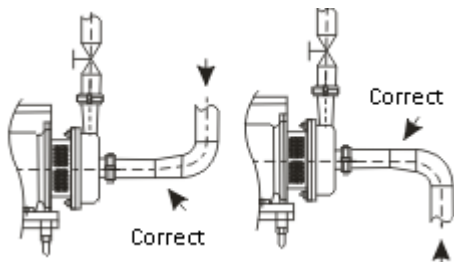

1. Suction tube should be as short as possible.

-
2. As few elbows as is better in the suction tube. The elbow with big radius of curvature ($R \geq 2D$) is a good choice.
 3. avoid air gathered in the suction tube or suck the air.

Step 5

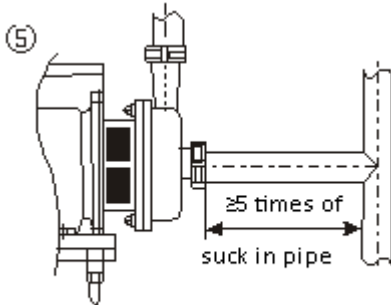

Ensure Fluid flow rate steady

Step 6

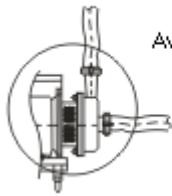

Avoid Stressing the pump

Support the inlet and outlet pipe properly and Avoid stressing the pump.

Pay special attention to:

- Vibrations of tube.
- Thermal expansion of the tubes.
- Excessive welding.
- Overloading of the pipelines.

3. Pre-use check

Step 1

- Always remove the impeller before checking the direction of rotation.
- Never start the pump if the impeller is fitted and the pump casing is removed.

-
1. Remove screws, gasket(16), and pump casing (9).
 2. Remove impeller (14) (see instruction of page 16).

Step 2

See the indication label!

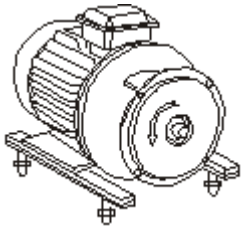

- 1 Start and stop the motor momentarily.
- 2 Ensure that the direction of rotation of the stub shaft (5) is anticlock-wise as viewed from the inlet side.

Step 3

1. Use a feeler to measure the clearance between the back cover and impeller.
2. If the clearance is not correct, please adjust it according to the methods mentioned in the article

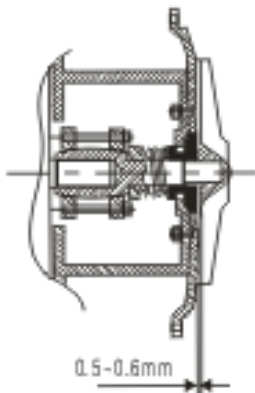

- ## Step 4
- Clean the impeller, and Fit and tighten impeller .

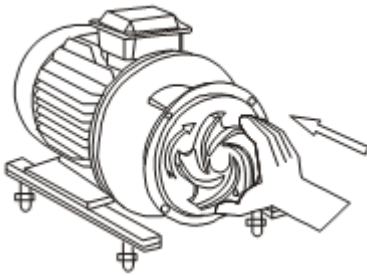

Step 5

- 1) install the pump according to structure drawing (page 17).
- 2) Clean pump casing and install it (9).
- 3) Install gasket and fit the screw (16)

III.Operation

1. Operation/Control

Step 1

The motor will be overload when the flow goes over the rated value since the resistance of the tube system become to smaller.

We cannot be held responsible for incorrect operation/control.

Step 2 Burning danger!

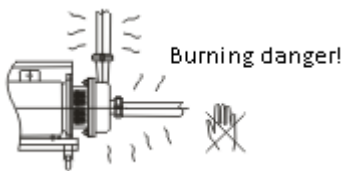

Never touch the pump or the pipelines when pumping hot liquids or when sterilizing.

Step 3 Explosion danger!

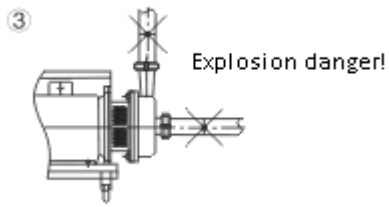

Never run the pump with both the suction side and the pressure side blocked.

Step 4

CAUTION! -The shaft seal must not run dry. Double seal pump, must feed in cool water before start pump.

-Never throttle the inlet side.

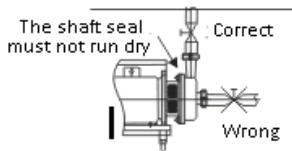

Step 5

cool water in

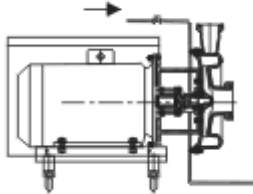

keep outlet open

Double Seal

1. Connect the inlet of the flushing liquid correctly.
2. Regulate the water supply correctly.

Step 6

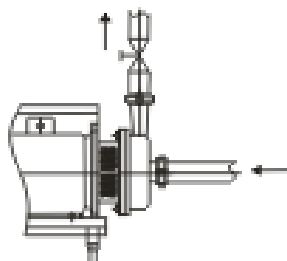

Control:

Reduce the capacity and the power consumption by means of:

- Throttling the pressure side of the pump.
- Reducing the impeller diameter.
- Reducing the speed of the motor.

2. Trouble shooting

NOTE!

Study the maintenance instructions carefully before replacing worn parts. - See page 12.

Problem	Reason	Solution
Motor overload	<ol style="list-style-type: none">1. low outlet pressure and too large flow rate2. -Pumping of viscous liquids3. -Pumping of liquids with high density4. Rotary speed of the motor is too higher.5. Lamination of precipitates from the liquid	<ul style="list-style-type: none">- throttling using outlet valve-Larger motor or smaller impeller-Check the frequency of the circuit.-Frequent cleaning
Flow small Shortage of lift No water pumped	<ol style="list-style-type: none">1. The pump and suction tube are unfilled with liquid.The impeller or pipes is blocked.2. Suction tube is leak.3. Pipe resistance exceeds the lift of pump.4. Lower voltage, small rotary speed of the motor.5. The liquid temperature is too higher.	<ol style="list-style-type: none">1. Check the bottom valve for leaks and refill it.2. Take apart the pump to remove the deposit.3. Reseal the suction tube.4. Reduce the pipe resistance or use the larger pump instead.5. Check the motor wiring and the voltage, frequency of the circuit.6. Decrease the liquid temperature or increase the pressure of the suction inlet or outlet.
Shock and noise increased to produce foul air	<ol style="list-style-type: none">1. The suction is shortage or the pressure of suction inlet is too lower.2. The liquid temperature is too higher.3. Suction tube is leak.4. There are foreign matters jam in impeller	<ol style="list-style-type: none">1. Reduce the resistance of the suction tube or the height of the suction inlet and liquid level.2. Reinstall the suction tube or replace the seals.

	<p>and pump shell.</p> <p>5. Fraction between the impeller and pump shell.</p> <p>6. The motor shaft is damaged.</p>	<p>3. Take apart the pump to remove the foreign matters.</p> <p>4. Adjust the clearance between impeller and pump shell.</p> <p>5. Replace the motor shaft.</p>
<p>Shaft seal is leak to cause foul air</p>	<p>1 Shaft seal working without liquid.(refer to page 6)</p> <p>2. Rotary or stationary ring worn-out</p> <p>3. O-shape seal ring is old or material selection is wrong.</p> <p>4. There are abrasives in the liquid.</p> <p>5. The material liquid is crystallized in the seal surface.</p>	<p>1. Replace all wearing parts to make sure the liquid material feeding continuous.</p> <p>2. Replace the rotary ring or stationary ring.</p> <p>3. Replace the O-shape seal ring or reselect the material.</p> <p>4. Stationary ring or rotary ring is made of silicon carbide or graphite.</p> <p>5. Take apart to clean the pump or use water to rinse the seal.</p>
<p>Rubber seal is leak.</p>	<p>Material of the rubber seal is selected wrong.</p>	<p>Reselect the material.</p>

3. Recommended cleaning

Step 1 Always handle alkali and acid with great care.

① Beware of the acid and alkali solution



Be sure to cover your hands with rubber gloves!



Be sure to wear safety glasses!

Step 2 Burning danger!

②

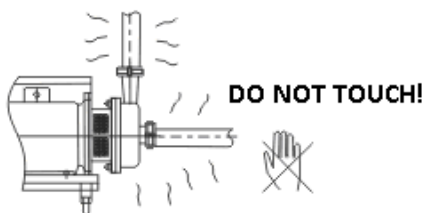

Never touch the pump or the pipelines when sterilizing.

Step 3 Examples of cleaning agents:

Use clean water, free from chlorides.

1. 1% by weight NaOH at 70° C (158° F).

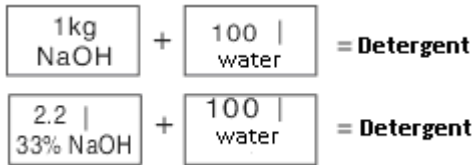

2. 0.51% by weight HNO₃ at 70° C (158° F).

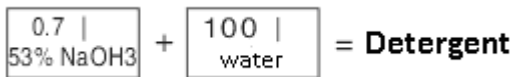

Step 4

1. Avoid excessive concentration of the Detergent

⇒ Dose gradually!

2. Adjust the cleaning flow to the process

Sterilization of milk/viscous liquids

⇒Dose gradually!

Step 5 Always rinse! Always rinse well with clean water after the cleaning.

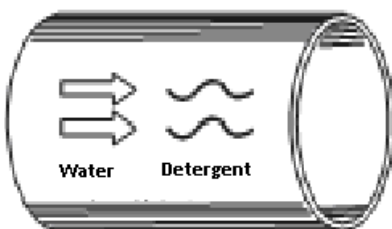

Step 6

NOTE!

The detergent must be stored/disposed of in accordance with current rules/directives.

IV. Maintenance

1. General maintenance

Step 1

Always follow technical data (see page 16).

Always disconnect the power supply when servicing the pump.

NOTE!

All scrap must be stored/disposed of in accordance with current rules/directives.

Step 2 Burning danger!

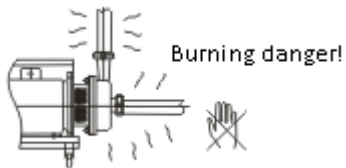

Never service the pump when it is hot.

Step 3 Atmospheric pressure required!

③

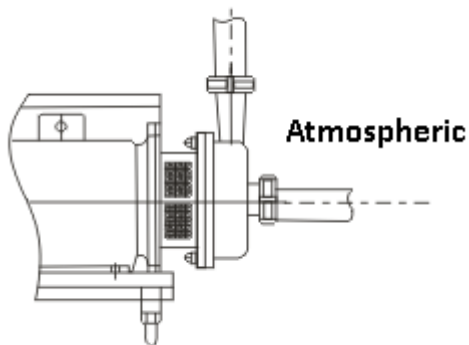

service the pump with pump and pipelines under atmospheric pressure.

Step 4 CAUTION!

Fit the electrical connections correctly if they have been removed from the motor during service (see pre-use check page4).

2. Maintenance

	Shaft seal	Rubber seal ring	Motor shaft
Preventive Maintenance	Replace all shaft seals every 12 months. (one shift) complete shaft seal	Replaced when replacing shaft seal	
Leakage	Replace at the end of the day. Complete shaft seal	Replaced when replacing shaft seal	
Planned Maintenance	-Regular inspection for leakage and smooth operation -Keep a record of the pump -Use the statistics for planning of inspections Replace after leakage: Complete shaft seal	Replaced when replacing shaft seal	Yearly inspection is recommended -Replace complete bearing if worn -Ensure that the bearing is axially locked (See motor instructions)
Lubrication	Before installation Lubricate the O-rings with sili-cone grease or silicone oil and Rubber seals	Before installation Silicone grease or silicone oil	With a long-term lubrication to bearing.

Pre-use Check Caution!

Fit the electrical connections correctly if they have been removed from the motor during maintainance. (page 4 of pre-use check)

1. Start and stop the motor momentarily.
2. Ensure that the pump operates smoothly.

3. Removal of the pump/shaft seal

- 1) Take off the nut (16), remove the gasket (10) and cover (9).
- 2) Take off the O-shaped ring (11) from the back cover.
- 3) Take off the coupling guard (6).
- 4) Thrust a screwdriver against the nut (12) of the coupling. Then turn the impeller (14) in an anticlockwise direction (Opposite the impeller) and remove the impeller. If it is necessary, adjust the blade of impeller to loose it.
- 5) Remove the rotary ring (18) from the impeller with the complimentary spanner. (Opposite the impeller, turn in an anticlockwise direction).
- 6) Double-end seal pump: Remove the water in and out tube.
- 7) Take off the locknut of the back cover, remove gasket (11) and pump body (10).

-
- 8) Double-end mechanical seal pump
 - a. Take off the auxiliary rotary ring from the water seal holder.
 - b. Take off the bolt from the pump body.
 - c. C. Take off the water seal holder and O shaped ring.
 - d. Take off the auxiliary rotary ring from the shaft (5).
 - 9) Take off the stationary ring and O shaped ring from the pump body.

4. Inspection of the pump shaft.

- 1) Measure the pulsation frequency of the shaft by the dial indicator.
- 2) If the pulsation frequency exceeds 0.06mm, the shaft seal should be replaced.

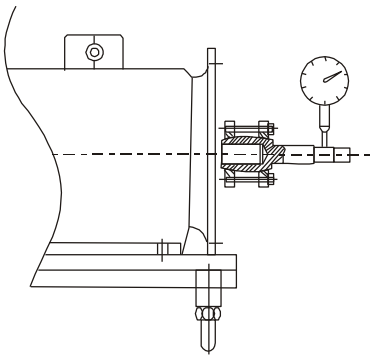

5. Reassemble of the pump

- 1) Double-end mechanical seal:
 - a) Lubricate the O shaped ring of the auxiliary stationary ring and put the rotary ring back to the shaft seal.
 - b) Press the auxiliary stationary ring into the water seal ring.
 - c) Lubricate the O shaped ring of the auxiliary rotary ring and install it to the shaft seal.
 - d) Put the water seal ring back to the pump body and tighten the bolt.
- 2) Install the pump body and tighten the nut. (Pay an attention to the inlet direction of the pump).
- 3) Lubricate the O-shaped ring of the stationary ring and screw it back to the pump body together with stationary ring. Tighten it with the spanner.
- 4) Screw the impeller back to the shaft (5).The clearance between the impeller and back cover should be 0.5-0.6mm.Adjust it by loosen the coupling bolt (4) if it is not correct. Tighten the bolt (4) after adjustment.

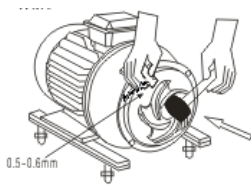

- 5) Lubricate O shaped ring (11) and round it to the pump body (9).
- 6) Double-end mechanical seal pump: Put back the water in and out tube.
- 7) Install the coupling guard.
- 8) Put the pump cover (9) back and screw the nut (16).
- 9) All bolts should be screwed according to the list below during installation:

	N.M					
Strength grade	M6	M8	M10	M12	M16	M20
8.8	10	25	49	85	210	420
A2-70	7.3	17	35	69	144	281

V. Technical data

Model: _____

Code: _____

Flow: _____ M³/h

Lift: _____ M

Max. pressure of inlet0.5Mpa

Working temperature.....-10~120°C (Fluorine rubber)

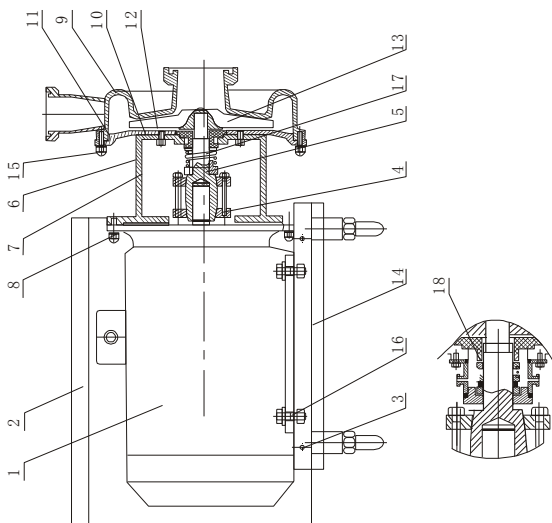

VI. Assembly sheet

Code	Qty	Items
1	1	Motor
2	1	Pump guard
3	4	Bolt, gasket
4	1	Coupling
5	1	shaft
6	1	Coupling guard
7	1	Connection base
8	4	Bolt, gasket
9	1	Pump cover
10	1	Pump body
11	1	O shaped ring
12	2	Nut, gasket
13	1	Impeller
14	2	Support
15	4/6	Bolt, gasket
16	4	Nut, bolt, gasket
17	1	Mechanical seal
18	1	Water cooled double-end seal